

V300 Series 3 1/4" Frame Depth Horizontal Slider

V300 SERIES HORIZONTAL SLIDER

FEATURES

- ◇ **Framing System**
 - 3 1/4" main frame
- ◇ **Enhanced Design**
 - Mitered and welded corners
 - Integral Nailing Fin
- ◇ **Glazing**
 - 1" insulating glass
- ◇ **Hardware**
 - Heavy-duty roller system
- ◇ **Screen**
 - Half screen
 - Extruded aluminum frame with BetterVue™ mesh with WaterShed® technology
- ◇ **Colors**
 - White or Sandstone vinyl (interior/exterior)

BENEFITS

- ◇ Perfect alternative product for commercial projects 8-stories and less. (up to 11 stories using receptor and subsill system)

PERFORMANCE

- ◇ Structural & Thermal (test reports and thermal simulations available upon request)

Model	Horizontal Slider
NAFS Rating	CW50
Design Pressure	50
Air Infiltration	<0.30
Water (No Penetration) P.S.F.	Up to 7.52
U-Value (based on multiple Low-E/Argon combinations)	As low as 0.25
SHGC (based on multiple Low-E/Argon combinations)	As low as 0.21

OPTIONS

- ◇ **Available Configurations**
 - Horizontal Slider
 - Center Vent Slider
 - End Vent Slider
 - Matching Fixed
 - Continuous frame capability
- ◇ **Muntin Choices**
 - Internal lites
 - Simulated Divided Lites
- ◇ **Screen**
 - Available without screen
- ◇ **Glazing**
 - Multiple Low-E and argon glazing choices
 - Capillary tubes
 - Wide variety of tinting and pane thickness options
- ◇ **Mulling**
 - Multiple mulling systems
- ◇ **Panning & Trim Choices**
 - Wide variety of panning, receptor, subsill and trim available
- ◇ **Colors**
 - High-performance Textured Black laminate (interior/exterior)
 - High-performance Textured Black laminate (exterior only with White vinyl or Textured Black laminate interior)
 - High-performance Textured Dark Bronze laminate (exterior only with White vinyl interior)
 - High-performance Resembles Clear Anodized laminate (exterior only with White vinyl interior)
 - Twelve painted exterior colors (with White or Sandstone vinyl interior)
 - Unlimited custom painted exterior colors

Our products are tested to the standards of and certified by some of the foremost organizations in the fenestration industry.



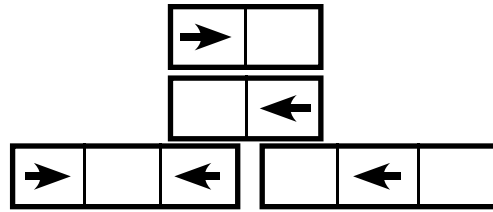

V300 Series 3 1/4" Frame Depth Horizontal Slider

V300 SERIES HORIZONTAL SLIDER

This document contains confidential and proprietary information intended for the private use of Quaker.
© 2021 Quaker Window Products Co., INC. All rights reserved.
Quaker reserves the right to change any/all designs without notice. Due to periodic re-certification requirements, result shown may vary.

1 HORIZONTAL CROSS SECTION

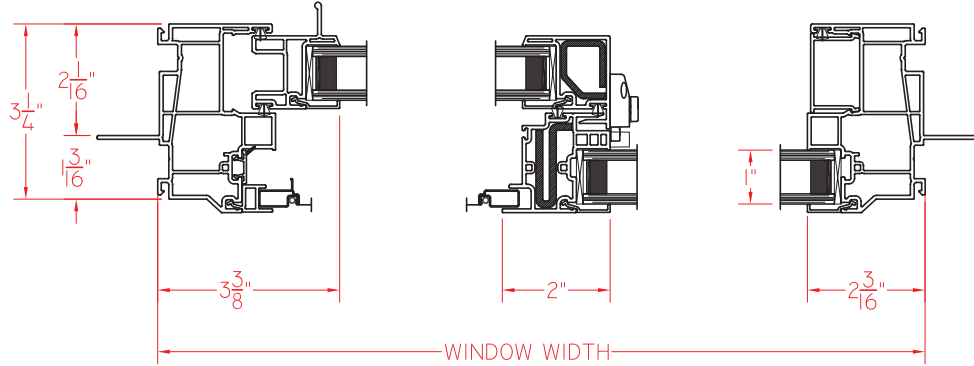

3 VERTICAL CROSS SECTION

2 VERTICAL CROSS SECTION

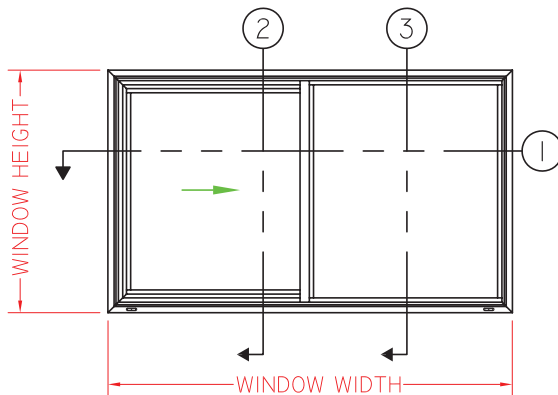

ELEVATION SCALE 1/2" = 1'-0"

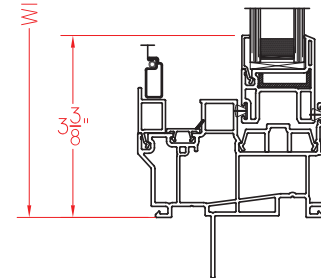
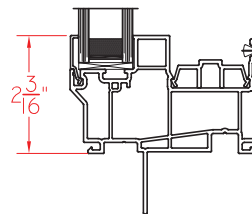
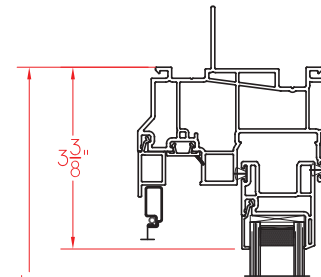
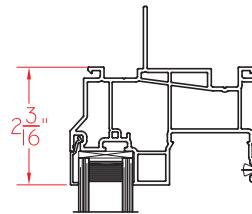

SCALE 1:3

Our products are tested to the standards of and certified by some of the foremost organizations in the fenestration industry.

