

T500 SERIES SINGLE HUNG

FEATURES

- ◇ Commercial Framing System
 - 3 1/4" main frame
 - 0.062" wall thickness of frame and sash
- ◇ Thermally Enhanced Design
 - Azon pour and debridge thermal break is 1/2" wide in all main frame and vent rail extrusions
 - Double fin-type weatherstripping
 - Full width lift handles
- ◇ Glazing
 - 1" insulated glass
- ◇ Hardware
 - Block and tackle balancers
 - Gravity latch
- ◇ Screen
 - Extruded aluminum screen frame with BetterVue™ mesh with WaterShed® technology

BENEFITS

- ◇ The capacity to match exterior colors for unique project facades
- ◇ The ability to facilitate large sizes for taller and wider window openings

PERFORMANCE

- ◇ Structural & Thermal (test reports or thermal simulations available upon request)

OPTIONS

- ◇ Available Configurations
 - Single hung
 - Oriel single hung
- ◇ Muntin Choices
 - Internal or simulated divided lites available
- ◇ Hardware
 - Class 5 balancers
 - Limited travel latch
- ◇ Nailing Fin
- ◇ Screen
 - Extruded aluminum screen frame with aluminum wire mesh
 - Extruded aluminum screen frame with sunscreen mesh
 - Extruded aluminum screen frame with stainless steel 0.009" thickness mesh
 - Security screen
- ◇ Glazing
 - Multiple Low-E and argon glazing choices
 - Capillary tubes
 - Wide variety of glazing, tinting and thickness options
- ◇ Panning & Trim Choices
 - Wide variety of panning, receptor and trim available
- ◇ Mulling
 - Wide variety of structural mulls
- ◇ Specialty
 - Attached exterior or interior storm window
 - Extension jambs

Model	Single Hung
NAFS Rating	AW-PG50
Structural Load P.S.F.	75.19
Air at 50 MPH (cfm/ft ²)	<0.10
Water (No Penetration) P.S.F.	10.03
U-Value (ranges based on multiple Low-E/Argon combinations)	0.37 - 0.43
SHGC (ranges based on multiple Low-E/Argon combinations)	0.14 - 0.50

Window test size: 60" × 99"
Operating Force: 19 lbf (maintain motion), 1 lbf (gravity latches)



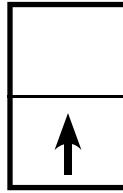

T500 Series 3 1/4" Frame Depth Single Hung

T500 SINGLE HUNG WITH NAILING FIN

This document contains confidential and proprietary information intended for the private use of Quaker.
© 2016 Quaker Window Products Co., INC. All rights reserved.
Quaker reserves the right to change any/all designs without notice.
Due to periodic re-certification requirements, result shown may vary.

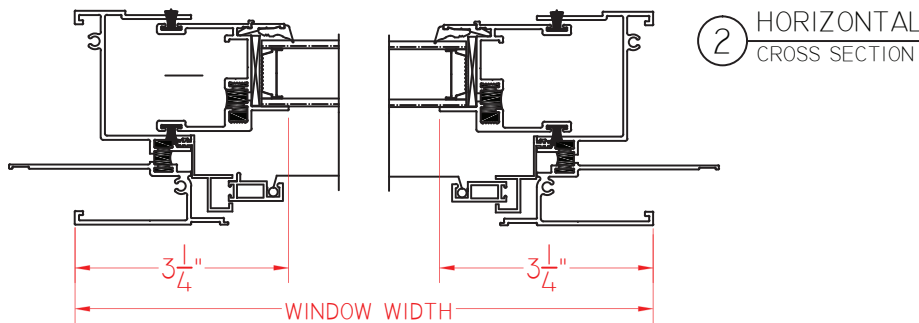
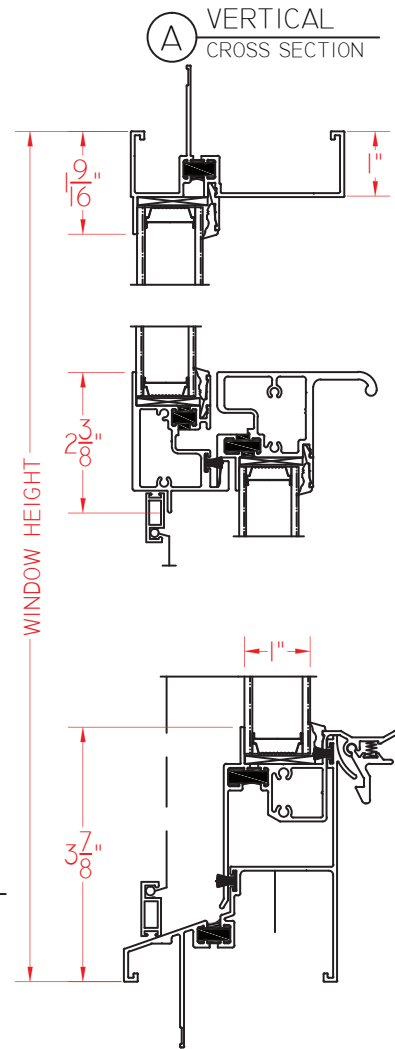
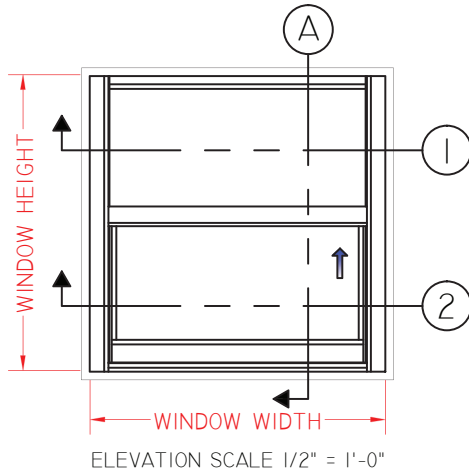
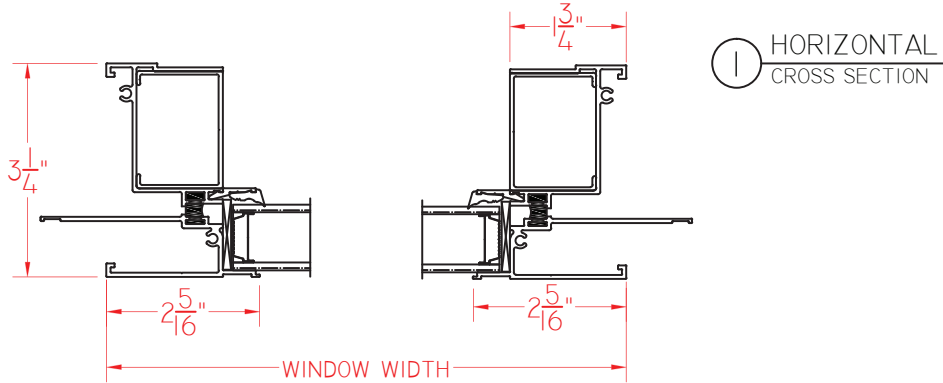

Our products are tested to the standards of and certified by some of the foremost organizations in the fenestration industry.



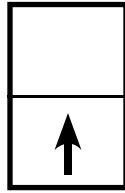

**T500 Series
AW-PG50
3 1/4" Frame Depth
Single Hung**

T500 SINGLE HUNG WITHOUT NAILING FIN

This document contains confidential and proprietary information intended for the private use of Quaker.
© 2016 Quaker Window Products Co., INC. All rights reserved.
Quaker reserves the right to change any/all designs without notice.
Due to periodic re-certification requirements, result shown may vary.

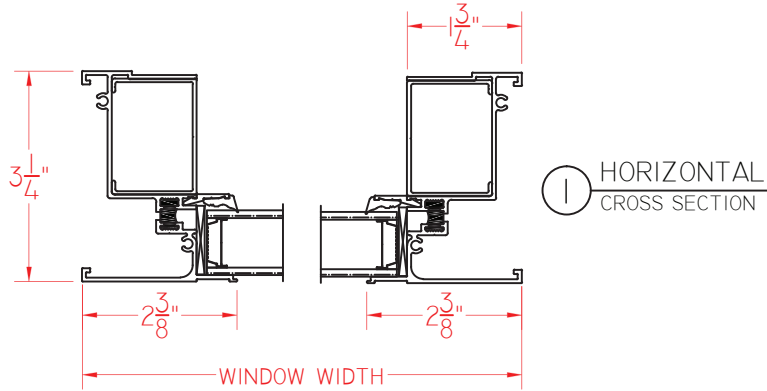

Ⓐ VERTICAL CROSS SECTION

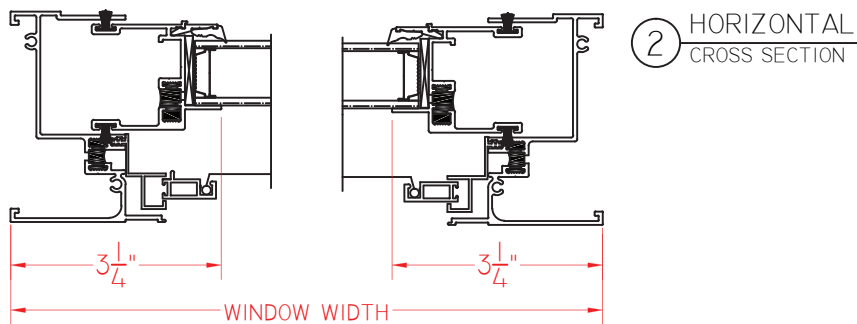
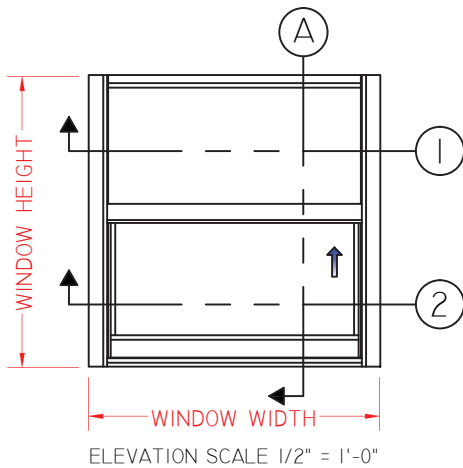
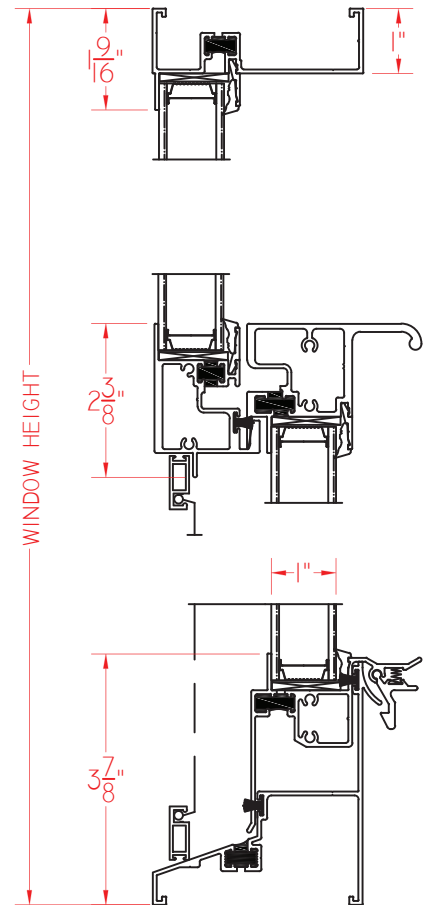

Our products are tested to the standards of and certified by some of the foremost organizations in the fenestration industry.

