



www.quakerwindows.com



www.quakercommercialwindows.com

PO Box 128 | 504 Highway 63 South | Freeburg, MO 65035 | 800-347-0438 | 573-469-4151 (fax)

Installation Guidelines for M-Series Terrace Inswing and Outswing Doors Anchored Through Jamb with Positioning Fin.

Read these instructions completely before starting any installation. Failure to install and maintain our product according to these instructions may void any product warranty. Please visit our website at www.quakerwindows.com or call 1-800-347-0438 for additional information.

Tools required by installer:

Safety glasses		Utility knife	
Drill/Driver		Caulk gun	
Level		Tape measure	
Hammer		J-roller	
Putty Knife		Staple Gun	

Materials required by installer:

Foam Backer Rod		Minimally Expanding Foam	
Shims (Waterproof)		Sealant	
Flashing tape (Self-Adhering)		Water Resistive Barrier/House Wrap (WRB)	
Fasteners		Denatured Rubbing Alcohol	
		Drip Cap	

⚠ WARNING

Tools

- Follow manufacturers instructions for safe operation of tools, and ladders/scaffolding. Always wear safety glasses. Failure to do so could result in injury, product or property damage.

Handling

- Do not store units outside, or in a hot environment. Doing so could result in product damage.
- Do not carry flat.** Doing so could result in product damage, injury, or property damage.
- Stack units as straight as possible to avoid bowing. **Do not lay flat!**

Glass

- If broken, glass can fragment causing injury. All Quaker products are available with safety glass. In many areas, local building codes require safety glass in certain locations and/or applications. Unless safety glass is ordered, Quaker windows are not provided with safety glass. Before ordering, consult your local building codes for more definitive information.

Fastening

- Metal fasteners and components could corrode when used with preservative-treated lumber. Use approved fasteners and components to fasten window or door. Failure to do so could cause a failure resulting in injury, product or property damage.
- Fastener must attach to a structural framing member with 1 1/2" minimum fastener embedment, or minimum 3 full threads with a minimum 5/16" head as products were tested with.
- Quaker does not supply anchorage/fastener calculations, and is not responsible for determining structural adequacy of the anchorage and fasteners used to install our products, or the openings into which they are installed.**
- Do not over drive screws or nails.** Doing so could result in product damage.

CAUTION
Installation

- Always support window or door in opening until fully fastened. Failure to do so could result in the window or door falling out or causing injury, product, or property damage.
- Nailing flanges and drip caps (integral or applied) **do not** take the place of window flashing. All windows and doors must be properly flashed and sealed with material compatible sealant for protection against water and air infiltration around the entire perimeter. Failure to do so could result in product or property damage.
- **Do not** set window directly on sill plate. Place shims under the side jambs. Window or door must be properly shimmed. Failure to do so could affect operation and product performance and could result in product damage.
- Live or dead loads transferred into our product can affect functionality, damage frame joinery or cause glass failures. Dead loads such as upper levels, roof, etc. Should be constructed before window or door is installed.
- Loads shall be designed to withstand the most critical effects of load factors and load combinations as required by the building code. (Loads are including but not limited to Live, Dead, Collateral, Auxiliary, Thermally induced, Seismic, etc.)
- Maximum vertical deflection of the header under all Load combination should not exceed the Span/720 or 1/4" whichever is less.
- Windows and doors have small parts. Small parts if swallowed could pose a choking hazard to young children. Dispose of unused, loose, or easily removed small parts. Failure to do so could result in injury.
- **Do not** drill through or into window sill to install alarm wires.

Sealing

- Follow instructions of foam, sealant, and flashing manufacturers regarding safety, material application, compatibility, and periodic maintenance for continued weather resistance of their products. Failure to do so could result in product or property damage. **DO NOT** overfill between the frame and opening.
- Minimally expanding foam insulation must be compliant with AAMA 812-04.
- Quaker recommends 100% silicone (ASTM C920 compliant) neutral cure only sealant. Always clean all areas where sealant will be applied. Failure to do so could result in product or property damage.
- Flashing tape must meet ASTM-D779 performance requirements.
- Maintain a minimum of 1/4" between the window or door frame and exterior finish materials. Failure to do so could result in product or property damage.

Joining

- Do not join any window or door to any window or door not designed for joining. Joined windows and doors must be individually supported in the opening. Failure to do so could affect operation and product performance and could result in product or property damage.

Cleaning

- Acid solutions used for cleaning will damage glass, fasteners, hardware, and metal flashing. Protect these products and follow cleaning products manufacturers instructions. If acid contacts the window or door, wash all surfaces immediately with clean water.
- **Do not** use razor blades to clean glass surface. Glass damage could result.
- Clean glass using liquid glass cleaner.
- Clean frame, sash, panels, and insect screens using mild detergent and warm water with a soft cloth or brush.

IMPORTANT

- Buildings constructed prior to 1978 could contain lead paint which could be disturbed during window or door replacement. For more information on proper management of lead paint, go to: www.epa.gov/lead
- Care must be taken to properly recycle or dispose of old materials. Any recyclable materials should be separated from non-recyclable or hazardous materials. Please consult with local or state authorities regarding proper disposal of non-recyclable or hazardous materials.
- These are generic instructions intended to cover most common situations, which may not be appropriate for all installations due to building design, construction materials, or methods used and/or building or site conditions. Consult a contractor or architect for recommendations.
- Inspect all units for any damage or defects prior to installation. Contact the nearest Quaker distributor if there are any problems.

Note for Outswing Units

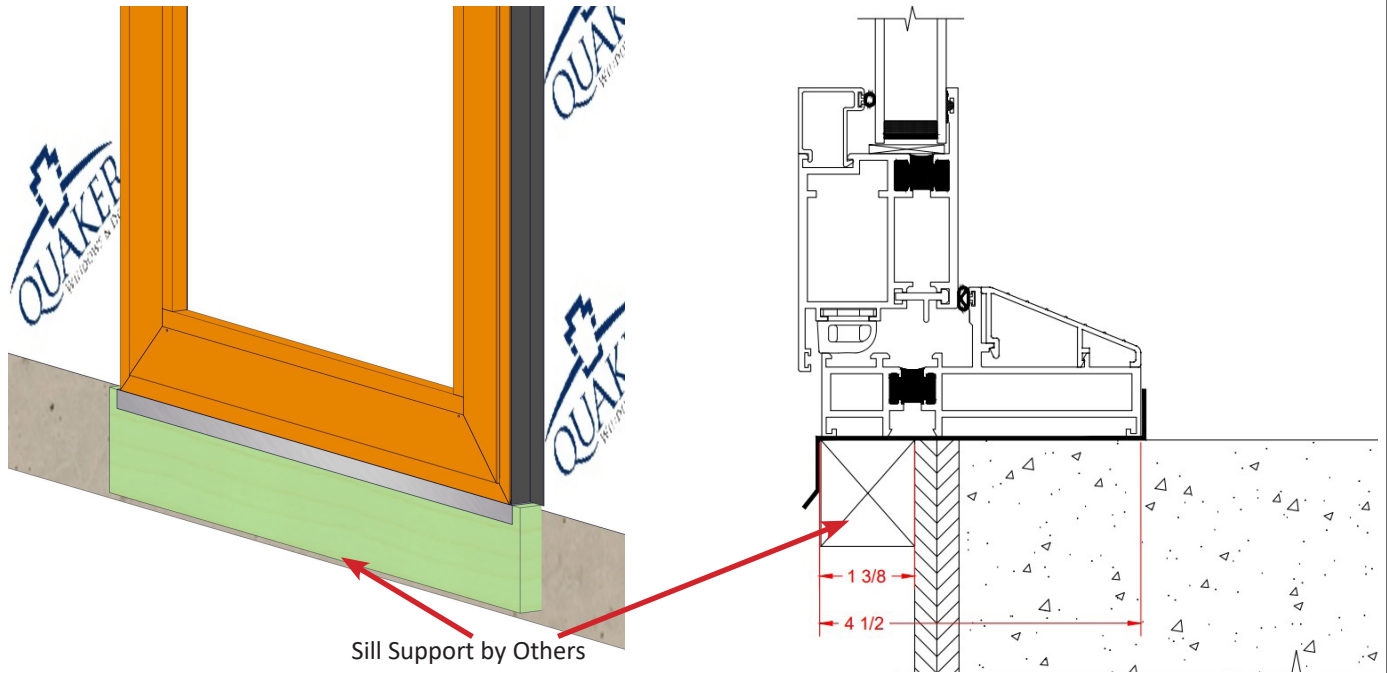

The sill must be supported the full width and depth of unit. For installations where the unit does not have full sill support, additional support must be installed under the sill.

Note for Inswing Units

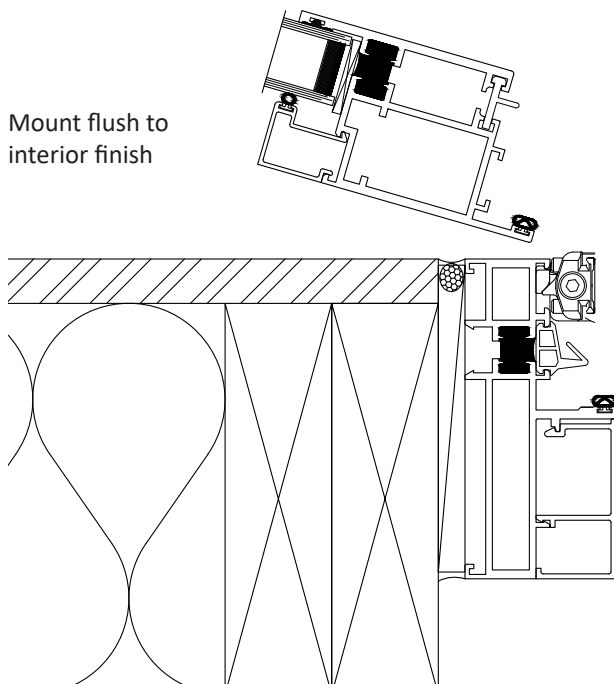

For inswing units where full panel operation is desired, install the unit flush with interior finish surface of wall.

Standard Sill

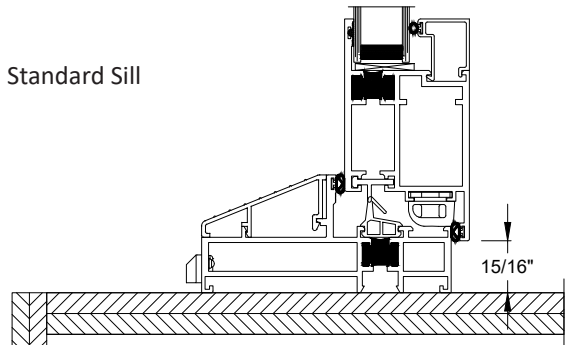

Low Sill

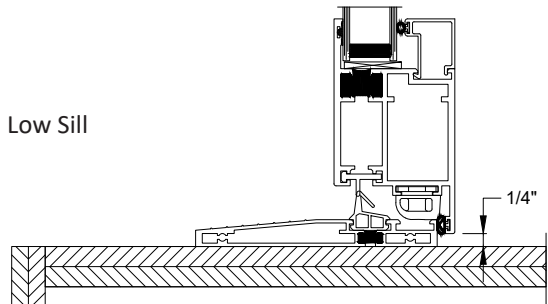

The panel must clear interior finishing material for proper operation. If the interior finishing material is greater than 1/4" for low sill units, or 15/16" for all other inswing units, raise door unit by placing waterproof shims or spacer under sill to gain sufficient clearance.



Allowances must be made in height of rough opening.

1

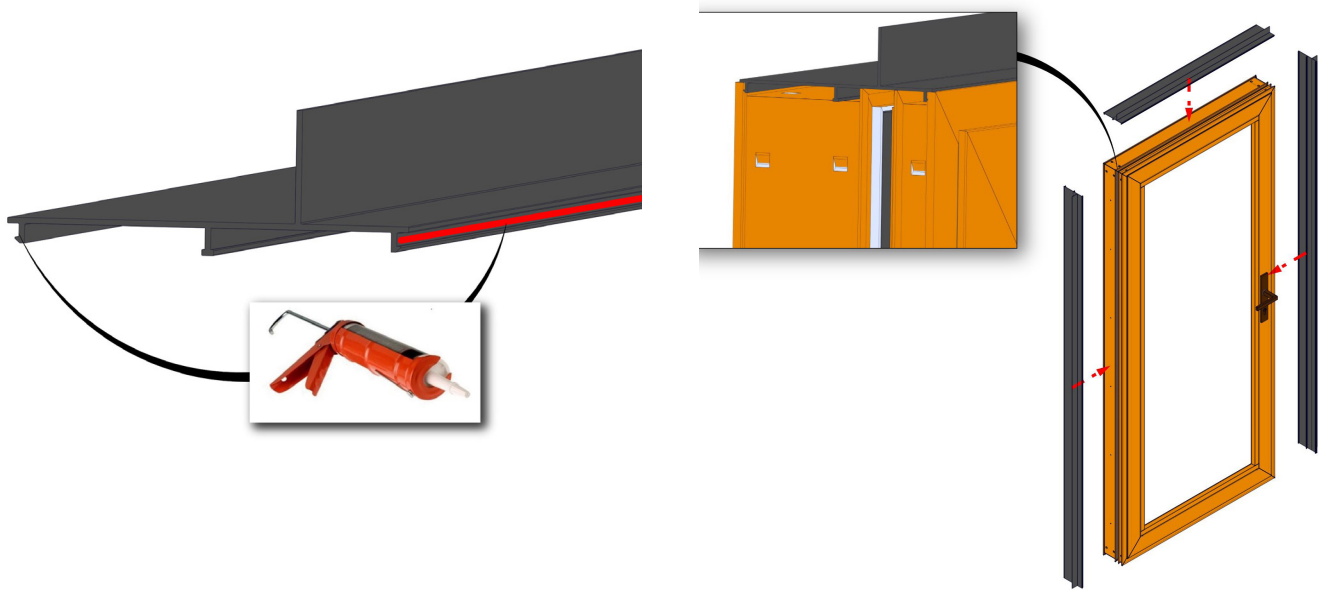

Apply sealant on the exterior legs of the positioning fin as shown above, and install the positioning fin into place with the short side of the flange facing the exterior.



For best recommended results, apply and seal all positioning fins 24 hours prior to door installation.

2

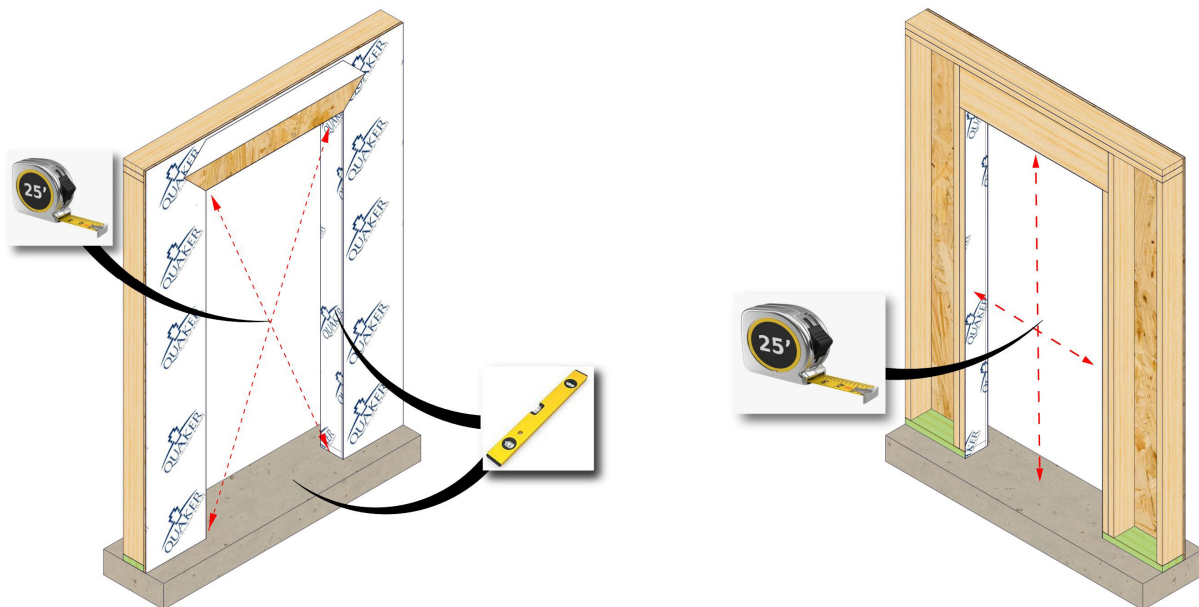

Measure and verify the size of the rough opening. The rough opening should be a 3/4" wider than the unit, and 1/2" taller. Verify the rough opening is flat, plumb, level, and square. **The sill beneath the unit must be level for proper unit operation.** Check the fit of the sill pan flashing system making sure the conditions are level. The installer can pre-apply the shims to the sill condition prior to installation of the sill pan flashing system. When shims are applied, verify door unit will clear header. Adjustments to header and rough opening might be required when shimming under the door unit.

3

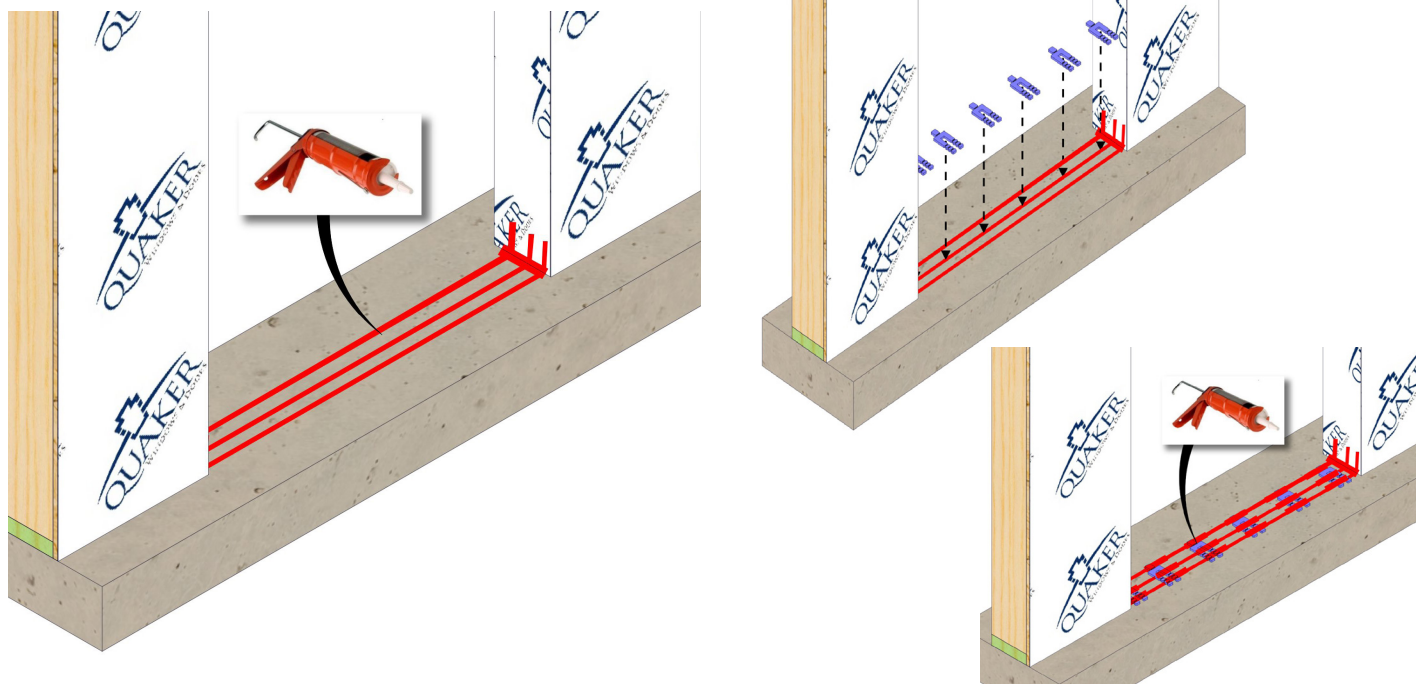

Apply three continuous 3/8" beads of sealant on the sill where the pan flashing will set. Also generously apply sealant along the bottom corners of the rough opening. Set shims in the bed of sealant and apply more sealant over the top of the shims.

4

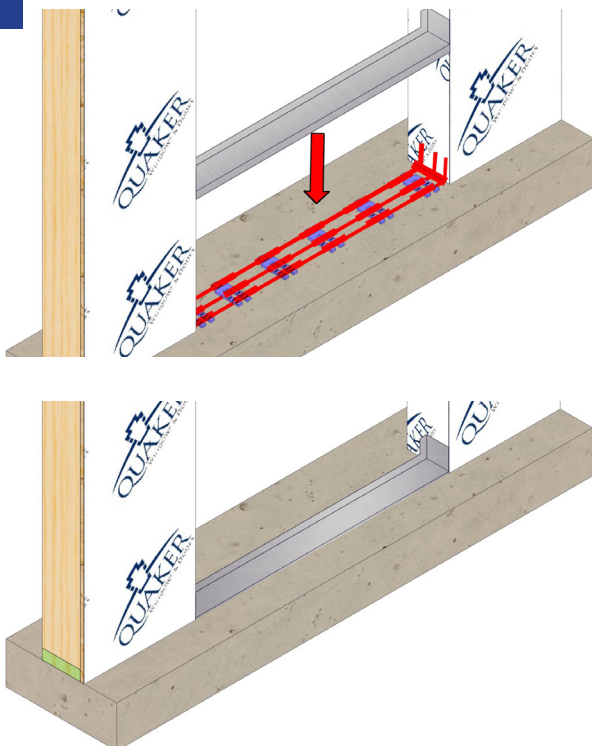

Apply sill pan flashing. The flashing must extend to the exterior face of the wall.

5

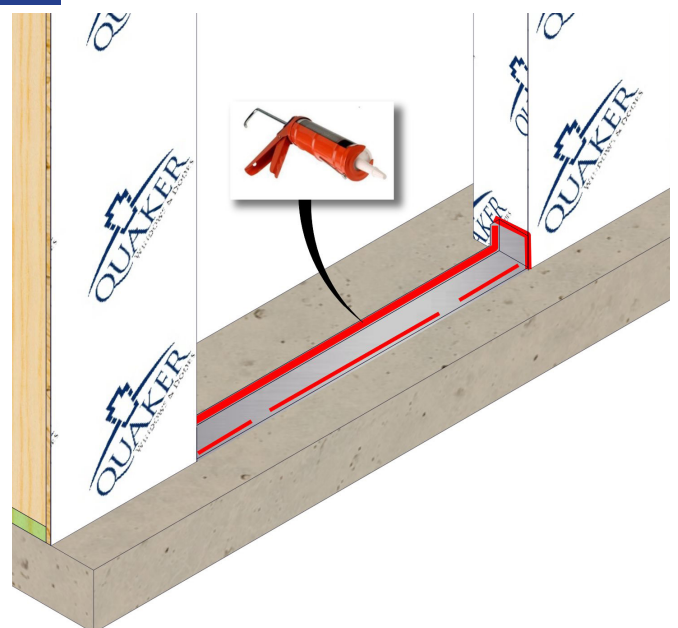

Apply a continuous bead of sealant to the exterior face of the upturned leg of the sill pan. Also seal where the sill pan flashing meets the rough opening, and tool sealant over any fasteners used to install the pan. Apply a discontinuous bead of sealant across the front of the sill pan flashing where the front of the door will set.

6

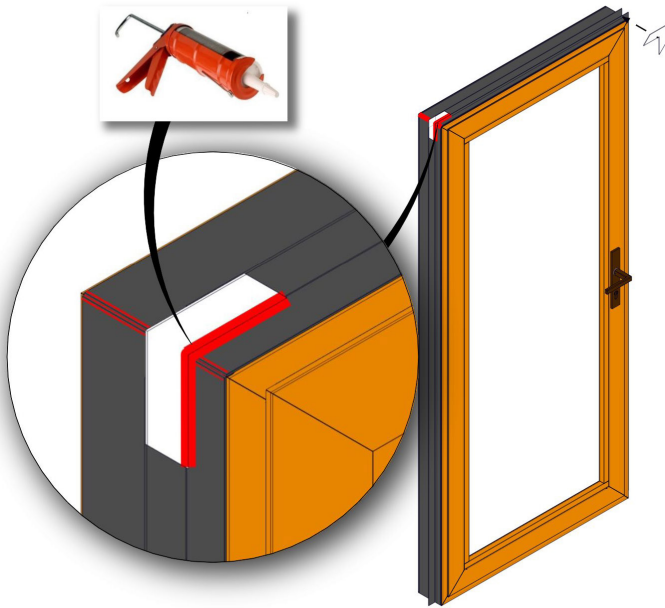

Install the two top foam corner key gaskets over the exterior side of the positioning fin corner gaps. Seal the exterior corners where the gasket meets the positioning fin as shown above.

7

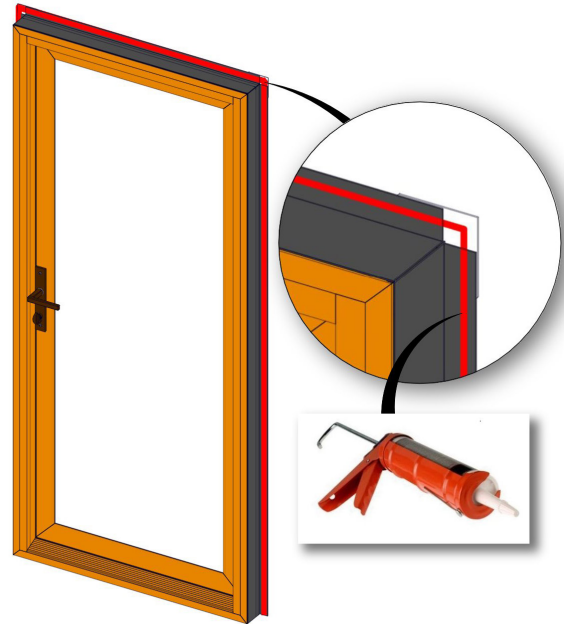

Apply a continuous 3/8" bead of sealant around the perimeter of the interior side of the positioning fin as shown.

8

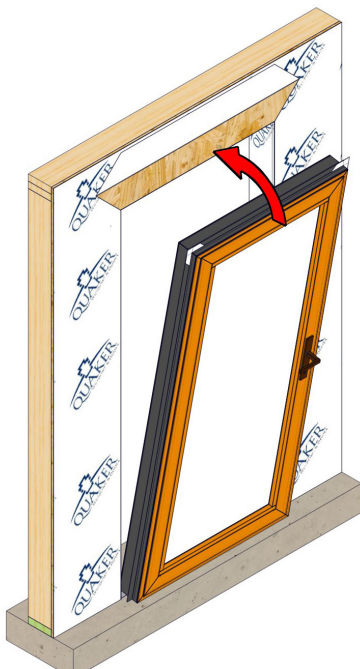

Center the door in rough opening, lifting and setting the bottom of the door in first, then tilting into place.. Verify for squeeze out of sealant all along positioning fin.



DO NOT nail or fasten through the positioning fin!

9

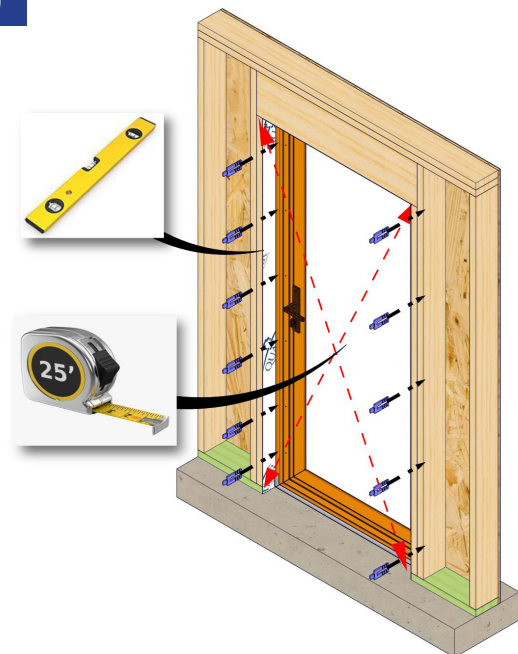

Square, level, and plumb unit in the rough opening by applying shims as needed. Shim behind all hinges and lock points, do not over shim, do not shim at the head.

10



Drill a pilot hole through the jamb's walls per anchorage calculations. **Quaker Window Products does not supply or claim liability for anchorage/fastener calculations. It is the installer/client's responsibility for structural adequacy of the anchorage and fasteners.** Typically, a #12 screw 6" from the top and bottom and 16" on center thereafter. Install and fasten the door unit in place using fasteners by others per anchorage calculations.

Always follow the anchorage calculations and fastener/anchor manufacturer's guidelines for proper edge distance, load capacity and installation techniques. **Do NOT overtighten fasteners.**

11



Install the jamb covers, then the head cover and threshold.

12

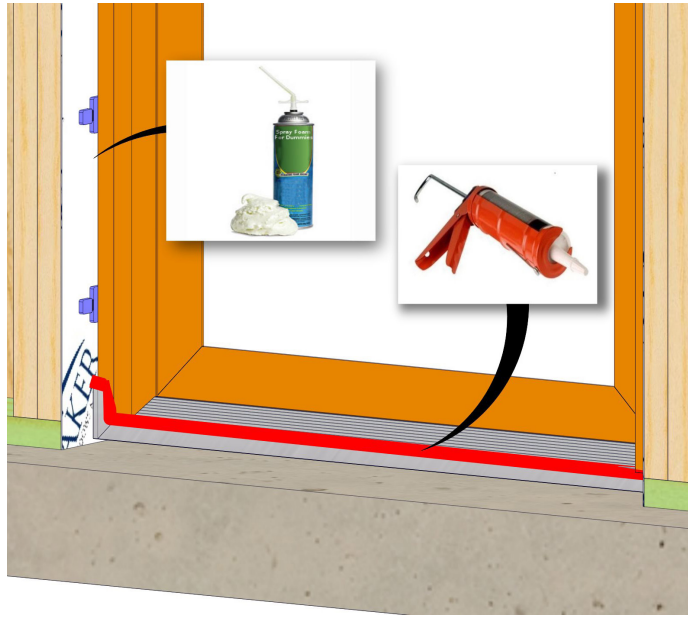

Apply a bead of sealant to fill the gap between the sill pan flashing system and the door unit. Make sure to seal all the way up both ends of the corner mold against the door. Insulate around the entire perimeter of the door.

13



Cut two pieces of flashing tape for jamb flashing extending 1" above the head positioning fin. Apply flashing tape and smooth using J-roller.

14

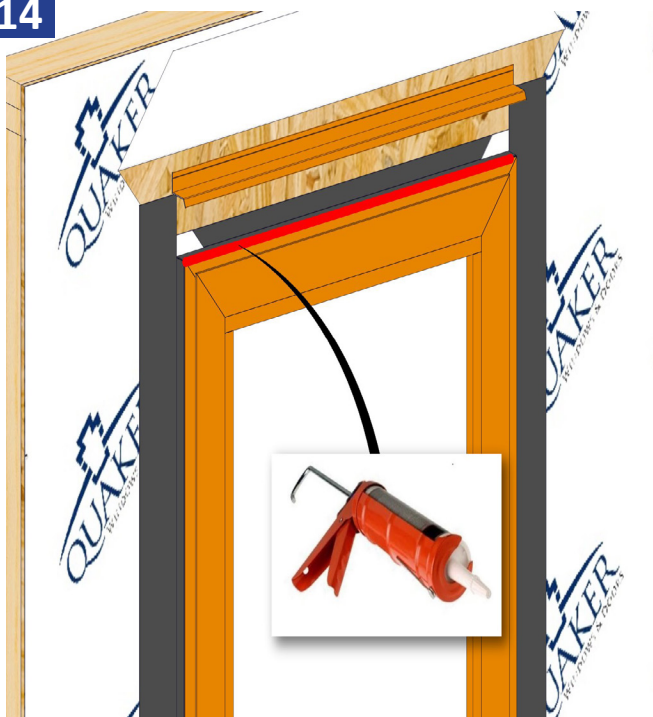

Apply a 3/8" bead of sealant to the top exterior edge of door frame before installing the drip cap as shown.



Place the drip cap the full width in sealant as shown.

15



Apply flashing tape over the drip cap leg, overlapping the side flashing as shown. Smooth using a J-roller.

 Side flashing cannot extend above the top flashing. Doing so could result in product or property damage.

16



Flip down upper flap of the weather resistant barrier so it lays flat across head flashing and tape the angle cuts as shown above.



Installation Guidelines For M-Series Terrace Inswing and Outswing Doors Anchored Through Jamb with Positioning Fin.

If this set of instructions doesn't match your installation method or wall conditions please check our website listed below for other options, or call the office.

Scan here for a digital version of these guidelines in English



Scan here for a digital version of these guidelines in Spanish



Or go to: <http://quakerwindows.com/installation-instructions/>

Or go to: <http://quakerwindows.com/installation-instructions-spanish/>



www.quakerwindows.com



www.quakercommercialwindows.com